



SPECIFICATION FOR LCD PRODUCT N° 903.02291

TABLE OF CONTENTS

- 1. PURPOSE 2**
- 2. PRODUCT SPECIFICATIONS..... 2**
 - 2.1 Basic Specification 2
 - 2.2 Mechanical Characteristics 2
 - 2.3 Absolute Maximum Ratings..... 2
 - 2.4 Electrical Characteristics 2
 - 2.5 LCD Electrical & Optical characteristics 3
 - 2.5.1 Definition of optical characteristics 4**
 - 2.5.2 Definition of viewing angle..... 5**
 - 2.5.3 Definition of response time 5**
 - 2.6 Assembly Drawing..... 6
 - 2.7 Pin connection (signal function)..... 7
- 3. RELIABILITY 7**
 - 3.1 Reliability 7
 - 3.2 Liquid Crystal Panel Service Life..... 7
- 4. MARKINGS 7**
- 5. SHIPMENT METHOD 7**
 - 5.1 Internal Packaging..... 7
 - 5.1.1 Labels..... 7**
 - 5.2 External Packaging 8
 - 5.2.1 Label Format 8**
- 6. RECEIVING INSPECTION..... 8**
- 7. QUALITY ASSURANCE 8**
 - 7.1 Conformity 8
 - 7.2 Responsibility 8
 - 7.3 Shipping Inspection Standards..... 8
 - 7.3.1 Shipping Inspection Standards..... 8**
 - 7.3.2 Zone Definitions 9**
 - 7.3.3 Visual Inspection 9**
 - 7.3.4 Limit Sample..... 9**
 - 7.3.5 Individual Appearance Defects Standards (Display OFF) 10**
 - 7.3.6 Individual appearance defects standards (display ON) 11**
 - 7.3.7 Chipped Glass Defect Standard 13**
 - 7.3.8 Electro-optical Test Procedure 13**
- 8. OPERATIONS PRECAUTIONS 14**
 - 8.1 Safety 14
 - 8.2 Handling 14
 - 8.3 Mounting and Design 14
 - 8.4 Storage..... 14
 - 8.5 Cleaning 14
- 9. SPECIFICATION HISTORY 15**
- 10. CUSTOMER APPROVAL 15**



1. PURPOSE

This specification covers the delivery requirements for the liquid crystal display module delivered by EM Microelectronic-Marin SA..

2. PRODUCT SPECIFICATIONS

2.1 BASIC SPECIFICATION

ITEM	CHARACTERISTICS
Display mode	FSTN
Display type	Positive, reflective or transfective
Viewing angle	6 o'clock
Driving	$1/81$ duty $1/10$ bias
LCD Driver	EM 6126
LCD Module structure	Standard : LCD + COG + HSC Options : zebra, backlight, frame, ...
Printing	On demand

2.2 MECHANICAL CHARACTERISTICS

ITEM	CHARACTERISTICS
Dots configuration	102x80 full dot matrix
Dots dimensions (mm)	0.265 H x 0.265 W
Dots gap (mm)	0.025
Module size (L x W x T, mm)	37.5x38
Glass thickness	0.7mm
Viewing area (L x W, mm)	32.5x27.1
Weight (g)	4.5g

2.3 ABSOLUTE MAXIMUM RATINGS

Vss = 0 V, Ambient Temp.= 25 °C

Item	Symbol	Condition	Min	Max	Unit
Power supply voltage	Vdd	25 °C	-0.3	+3.6	V
	Vlcd	25 °C	-0.3	+12	V
Input voltage	Vin	25 °C	.Vss – 0.3	Vdd + 0.3	V
Operating temperature	Topr	---	-20	+70	°C
Storage temperature	Tstg	---	-30	+80	°C

* Bubbles may occur at low temperature, but they disappear within two hours in room temperature, thus the LCD is not defective.

2.4 ELECTRICAL CHARACTERISTICS

Vss = 0 V, Ambient Temp.= 25 °C

Item	Symbol	Condition	Min	Typ	Max	Unit
Power supply voltage	VDD	25 °C	2.4	2.5	3.3	V
Operating Voltage (Vdd- Vlcd)	Vop	25 °C		9.0		V
Operating frequency (frame frequency)	fopr (FRM)	25 °C		70		Hz
Current consumption	Idd	Board pattern at 25 °C Partial mode	-	300	400	µA
				80		µA



2.5 LCD ELECTRICAL & OPTICAL CHARACTERISTICS

ITEM	SYMBOL	CONDITIONS	TEMP	MIN	TYP	MAX	UNIT
Contrast	C	$\theta = 10^\circ$ $\Phi = 0^\circ$ $V_{op} = 9.0V \pm 3\%$	25°C	-	6	-	-
Viewing angle	$\theta 1$	$C \geq 2.0$		-	-	-20	deg.
	$\theta 2$	$F = 180^\circ$	25°C	30	-	-	
	$\theta 2 - \theta 1$	$V_{op} = 9.0V \pm 3\%$		50	-	-	
Response time	ton	$V_{op} = 9.0V \pm 3\%$	25°C		250		ms
		$V_{op} = 9.0V \pm 3\%$	0°C		1000		
				-	-	-	
	toff	$V_{op} = 9.0V \pm 3\%$	25°C		200		
		$V_{op} = 9.0V \pm 3\%$	0°C		1500		
				-	-	-	

Measuring equipment: Autronic

2.5.1 Definition of optical characteristics

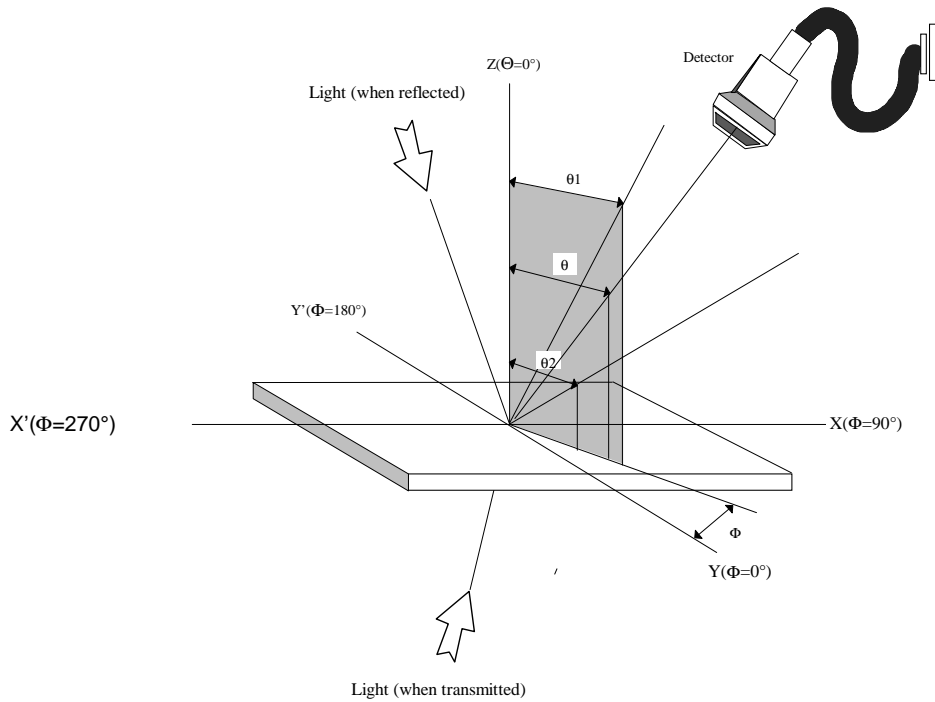

Definition of contrast Cr. $Cr. = \frac{B1}{B2} = \frac{\text{Brightness of not selected segment}}{\text{Brightness of selected segment}}$

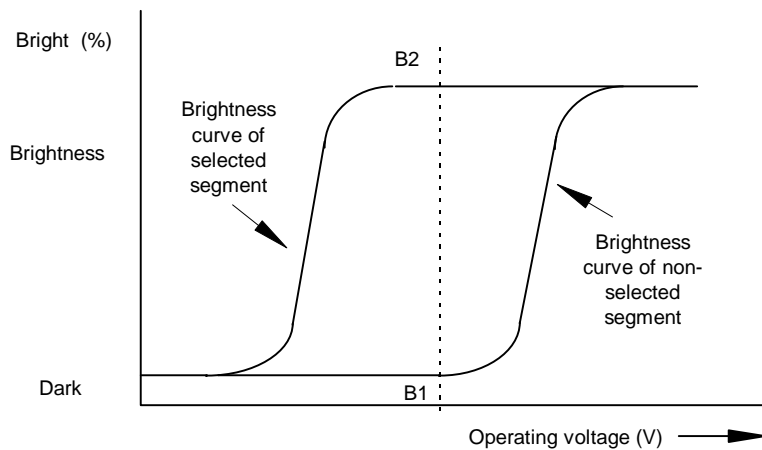

2.5.2 Definition of viewing angle

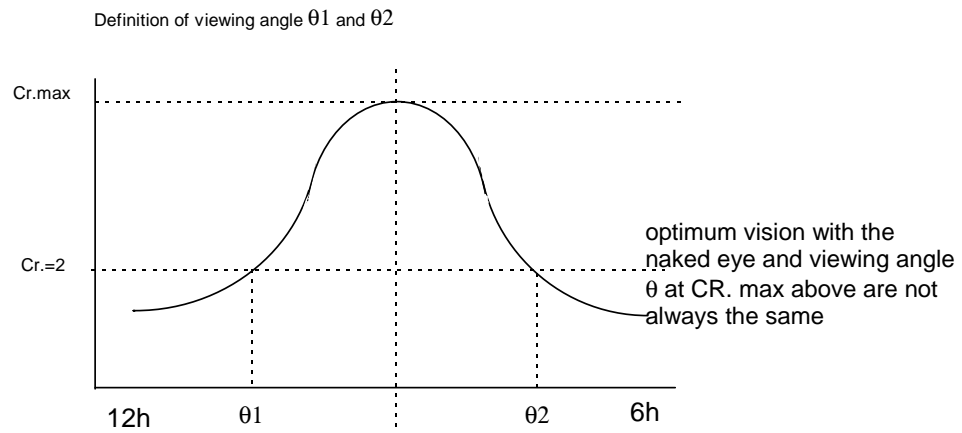

2.5.3 Definition of response time

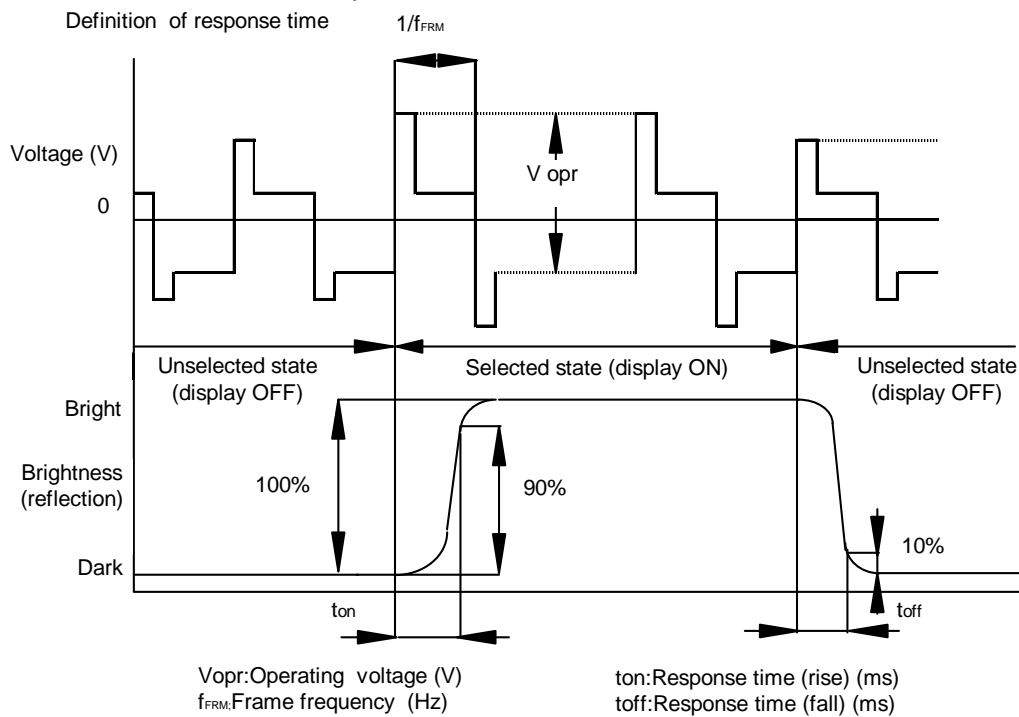

2.6 ASSEMBLY DRAWING

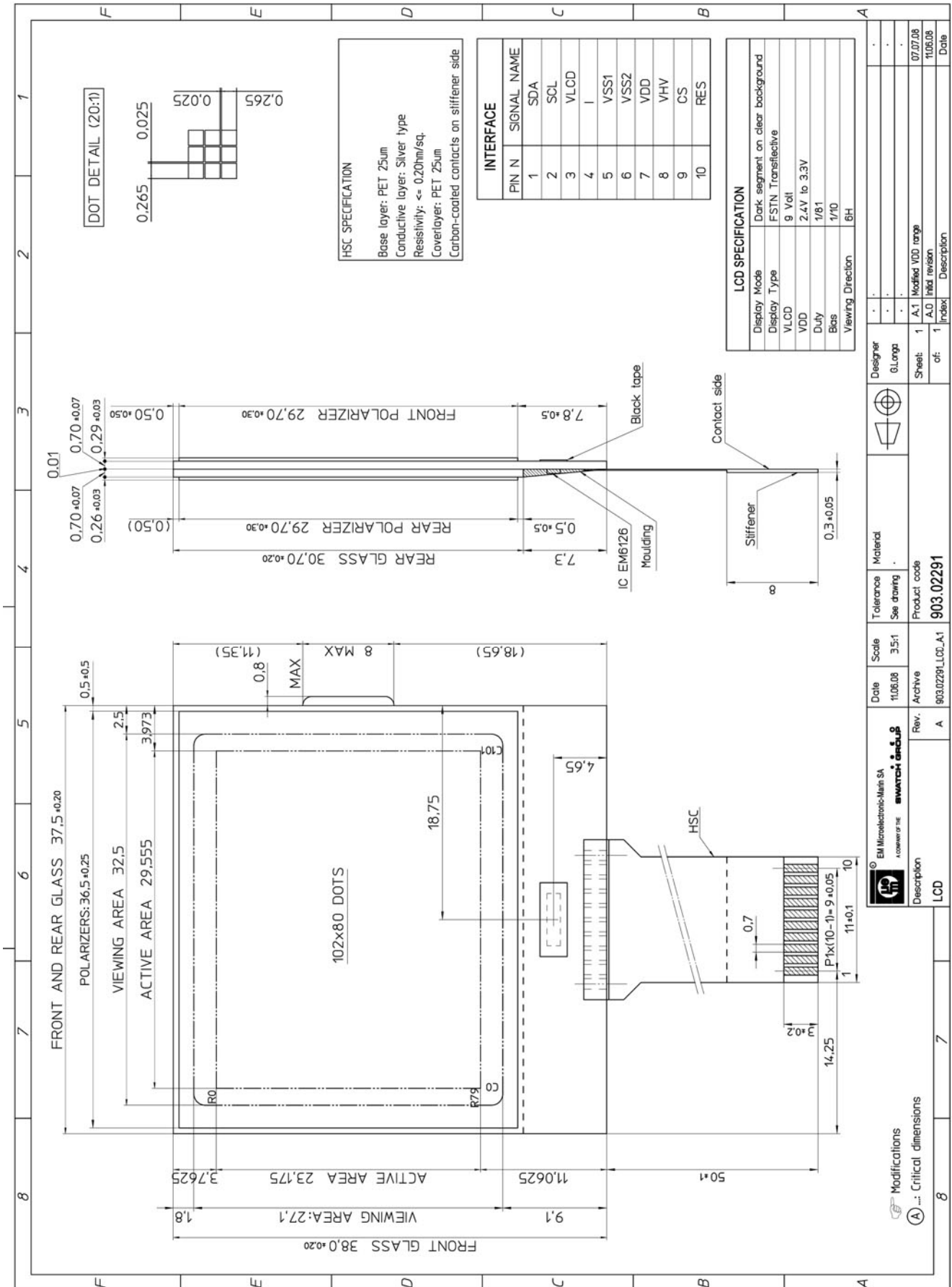



2.7 PIN CONNECTION (SIGNAL FUNCTION)

No.	Symbol	Function
1	SDA	Serial Data
2	SCL	Serial clock
3	Vlcd	LCD supply voltage
4	I	Interface protocol select
5	VSS1	Ground
6	VSS2	Ground
7	VDD	Logic supply voltage
8	VHV	High voltage generator supply voltage
9	CS	Chip select
10	RES	Reset

3. RELIABILITY

3.1 RELIABILITY

Storage Condition	Contents	Current Consumption	Oozing	Contrast	Other Appearances
Operation at high temperature and humidity	40°C/90%RH 500h	Twice the initial value or less	None	More than 50% of initial value	No abnormality
High temperature storage	60° ± 2°C 500h	Twice the initial value or less	None	More than 50% of initial value	No abnormality
Low temperature storage	-10° ± 2°C 500h	1.5 times the initial value or less	None	More than 50% of initial value	No abnormality

3.2 LIQUID CRYSTAL PANEL SERVICE LIFE

100,000 hours minimum at 25°C ± 10 °C, 65% RH max (only cell)

4. MARKINGS

EM 903.02291 on front polariser protection foil. Special markings on demand.

5. SHIPMENT METHOD

5.1 INTERNAL PACKAGING

The products are packaged with anti static partitions or cushions, to protect them from touching each other. Other packaging on demand.

5.1.1 Labels

Following information is described:

1. Lot No.: Shipping lot number
2. Part: Component name (EM 903.02291)
3. Quantity: Quantity of pcs



5.2 EXTERNAL PACKAGING

Products are shipped in labelled cartons.

5.2.1 Label Format

The format on the label is shown below. A progressive number is added near the label.

Cal.	←	Model name
QTY	←	Quantity
N/W	←	Net weight
G/W	←	Gross weight

6. RECEIVING INSPECTION

Receiving inspection at customer place has to be done within 2 weeks after receipt of the goods. Any products that do not conform to the LCD drawing and the delivery specification are dealt with in accordance with item "dealing with customer complaints" in EM General Terms of Sales (see EM Web Site)

7. QUALITY ASSURANCE

Also refer to EM General Terms of Sales and EM Web Site

7.1 CONFORMITY

The performance, functions and reliability of the shipped products conform to the product specifications.

7.2 RESPONSIBILITY

Customer is responsible for any defects in quality caused after receiving inspection.

7.3 SHIPPING INSPECTION STANDARDS

7.3.1 Shipping Inspection Standards

The sampling inspection plan is in accordance with MIL-STD-105D, single sampling, Inspection Level II and normal inspection. The quality assurance levels are shown below.

RANK	DEFECT	A.Q.L.
Major defect	No display Short circuit Outside dimensions	0.25%
Minor defect	Display missing Pattern misalignment Pattern protrusion Black spots, black streaks Bubbles Chromaticity and uniformity Polarizer defects Glass defects Dirt, spots	0.65%

7.3.2 *Zone Definitions*

Shipment inspection is performed under dividing zone A and B.

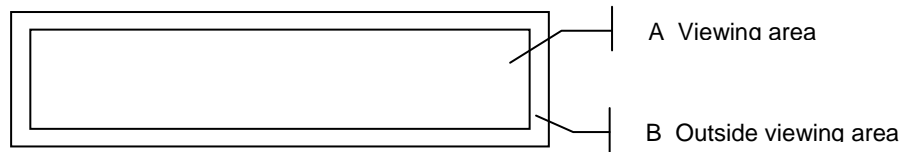

7.3.3 *Visual Inspection*

Inspect under 30W fluorescent lamp, leaving 30cm between panel and eyes, and between panel and lights.

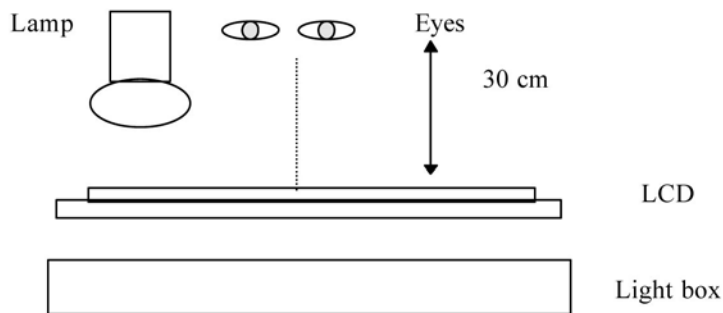

7.3.4 *Limit Sample*

If a judgement cannot be made according to the delivery specification, limit samples have to be organized.



7.3.5 Individual Appearance Defects Standards (Display OFF)

Φ Average diameter (mm), W: Width (mm), L: Length (mm)

No	Item	Details	Section		Standards, max no. of defects	
					Zone A	Zone B
1	Black spots		$< \Phi \leq 0.10$		Any number	Any number
			$0.10 < \Phi \leq 0.25$		3	
			$0.25 < \Phi \leq$		0	
			Total number of defects		3	
2	Black streaks		$W \leq 0.01$		Any number	Any number
			$W \leq 0.03$	$L \leq 5.0$	3	
			$W \leq 0.05$	$L \leq 2.0$	2	
			$W \leq 0.05$	-	0	
			Other than above		0	
			Total number of defects		3	
3	Chromaticity and Uniformity	Streaks and uneven colour caused by uneven gap between glasses			See limit sample	
4	Bubbles in polarizer	Bubbles between polarizer and glass	$0.20 < \Phi \leq 0.50$		3	Any number
			$0.50 < \Phi \leq 1.0$		1	Any number
			$1.0 < \Phi$		0	Any number
			$W \leq 0.15$	$L \leq 5.0$	2	Any number
			$W \leq 0.15$	$L \leq 10.0$	1	Any number
5	Scratched on the polarizer	Spots	$< \Phi \leq 0.10$		Any number	Any number
			$0.10 < \Phi \leq 0.25$		3	
			$0.25 < \Phi \leq 0.30$		1	
			$0.30 < \Phi$		0	
		Lines		See limit samples		
6	Dirt on the polarizer				See N.1, 2	
7	Polarizer dislocation				Products pass if the dislocation is out of viewing area	
8	End seal position				n/a	

7.3.6 Individual appearance defects standards (display ON)

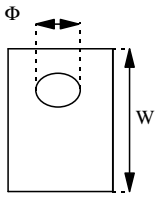
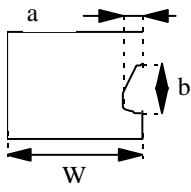
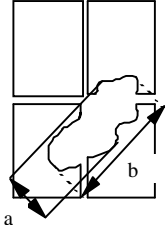
No	Item	Detail	Section (mm)	Standard. Max No of defects
1	No display	Part or all of the screen doesn't light because of an open or a short circuit		Must not occur.
2	Display missing	Part of display segment missing because of pin holes or an open. 		W=0.265
			$\Phi \leq 0.10$	Any number
			$0.10 < \Phi \leq 0.25$	3
			$0.25 < \Phi$	0
3	Display missing	Part of display segment missing because of pin holes or an open. 		W=0.265
			$a \leq 0.10$ $b \leq 0.10$	Any number
			$a \leq 0.20$ $b \leq 0.25$	3
			$a \leq 0.25$ $b \leq 0.30$	0
			$a > 0.25$ $b > 0.30$	0
4	Display missing a,b	Thin part of display segment / common missing 	$a \leq 0.03$	Any number
			$a \leq 0.05$ $b < 0.5$	3
			$a \leq 0.10$ $b \leq 0.3$	2
			$a \leq 0.20$ $b \leq 0.3$	1
			Other than above	0

7.3.7 Chipped Glass Defect Standard

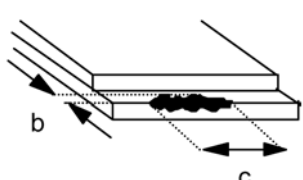
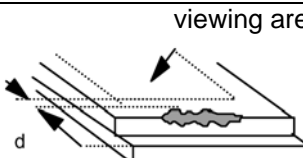
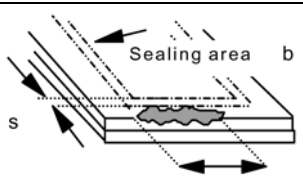
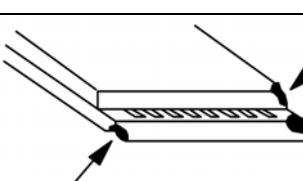
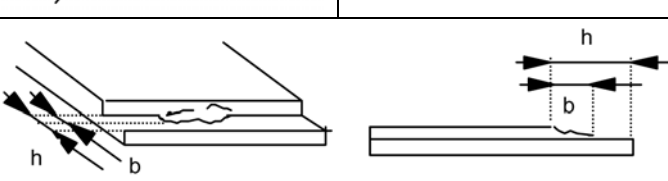
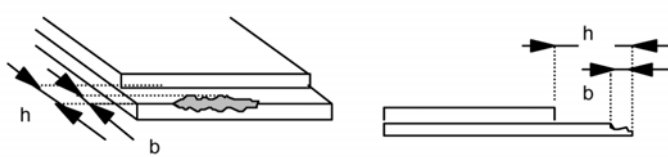
No	Item	Details	Section	Standards, max no. of defects
1	Chipped glass at lead terminals			More than 30% of lead terminal must remain
2	Chipped glass excluding terminals			Acceptable if the distance d between chip and the limit of the viewing area is $\geq 0.25\text{mm}$
3	Chipped glass on end face			Width 's' of seal remaining must be $\geq 0.5\text{mm}$; 'c' must be $< 10.0\text{mm}$
4	Chipped glass Other cases			Acceptable
5	Glass rest or insulating layer			$b \leq h/3$
6	Irregular cut			$b \leq h/3$ No glass rest

7.3.8 Electro-optical Test Procedure

7.3.8.1. Functionality

Functionality of LCD module is 100% controlled for the following test patterns:

- All on
- Checker
- Frame
- Frame with 4 lines of "H"

Test is passed if for:

- All on : All pixels are on
- Checker : Checker pattern complete
- Frame : 1 pixel wide frame around viewing area complete
- Frame with 4 lines of "H" : "H" rows + frame complete



7.3.8.2. *Current consumption*

Current consumption is 100% controlled and has to be within specification, as per table 2.4 Electrical characteristics.

8. OPERATIONS PRECAUTIONS

8.1 SAFETY

- If the LCD panel breaks, be careful not to get the liquid crystal in your mouth or in your eyes.
- If the liquid crystal touches your skin or clothes, wash it off using soap and water.

8.2 HANDLING

- The LCD is plate glass; do not hit or crush it.
- The polarizer of the display is very fragile; handle it very carefully.
- Do not soil or damage the LCD terminals.
- Keep the display surface clean. Do not touch it with your skin.

8.3 MOUNTING AND DESIGN

- When mounting, fix the external glass surface from sealing edge. If any force is applied where the liquid crystal is enclosed, uneven colour may occur because of the fluctuating of the LCD gap.
- If any force is applied to the polarizer, bubbles or separation may occur.
- Leave a gap so that the LCD, excluding the fixing portion, does not touch other components.
- Make a window smaller than the viewing area.
- To protect the LCD from external pressure, place a transparent plate (acrylic or glass) over the display surface having a small gap.
- Avoid condensation, otherwise the transparent electrodes may break.
- Drive with alternating drive, because the direct drive shortens the life of the LCD.

8.4 STORAGE

- For long-time storage, keep in a dark place at $25^{\circ}\text{C} \pm 10^{\circ}\text{C}$, 65% RH maximum.
- Do not store the LCD near organic solvents or corrosive gases.

8.5 CLEANING

- Do not wipe the polarizing plate with a dry cloth, as it may scratch the surface.
- Wipe the module gently with a soft cloth soaked with a perfluorine-hexane or iso-propanol.
- Do not use ketonic solvents (ketone and acetone) or aromatic solvents (toluene and xylene), as they may damage the plastic cover plate.



9. SPECIFICATION HISTORY

Rev.	E.C.N.	Pages	Date	Resp.	Description
A	08-0643	15	24.06.08	HA	New specification
B	08-0720	2, 6	11.07.08	HA	Change VDD range §2.3, 2.4, 2.6

10. CUSTOMER APPROVAL

Should EM not have received a written feed-back from you within 10 days from receipt of the above specification(s), such specification(s) shall be explicitly considered as approved and accepted by you.

Customer (print company name): _____

Approved by (print name): _____

Signature: _____

Title: _____

Date: _____

Please complete and return to:

**LCD & Module Department
EM Microelectronic SA
Rue des Sors 3
CH-2074 Marin**

Fax: +41 32 755 5918