



# Sensor Signal Conditioner with 14 bits A/D Converter

## All-in-one: Pressure, Temperature and Supply Voltage Detection

### Description

The EM6415 is an Ultra-Low Power Programmable Sensors Signal Conditioning Circuit, intended to be used as single chip interface between one to four resistive sensors and a microcontroller. In a classic sensor system, EM6415 completely replaces the sensor conventional electronic interface circuitry, while in a modern sensor system EM6415 can replace the external amplifier and the expensive A/D converter.

### Key Features

- ❑ Full Sensor System Solution on Chip
- ❑ No external discrete components for sensor interface, calibration or error compensation
- ❑ Programmable Sensor Offset, Gain and Linearity adjust
- ❑ Programmable current source for sensor supplies
- ❑ Programmable dual slope A/D converter (patented) with program selectable 10, 13 or 14 bits resolution

### & BENEFITS

- ✓ Ideal for multi-sensor applications
- ✓ High flexibility and easy-to-design compact sensor applications
- ✓ Ideal for portable applications with resistive sensors
- ✓ No more expensive sensor precalibration
- ✓ No longer need of a power consuming and costly high resolution ADC
- ✓ Save PCB space

### And more...

- ❑ On chip Ultra Low Noise Differential Input Amplifier with mask selectable gain
- ❑ High flexibility in Zero adjust and Full Scale Adjust
- ❑ Low Supply Voltage Range, 2.2V – 3.6V
- ❑ Low Operation Current, 240µA at 800kHz, 3V
- ❑ Ultra Low Power Consumption (in Standby Mode or After Conversion down to less than 0.1 µA)
- ❑ Delivery form: SSOP36 – 300mils , die

### Block Diagram

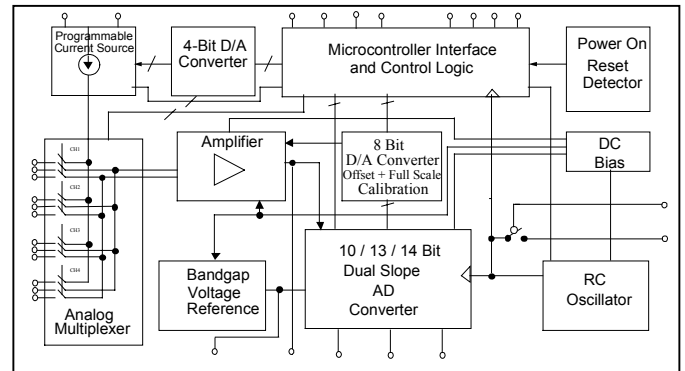

### Typical Applications

- ❑ Portable sensor instruments
- ❑ Telemetry
- ❑ Automotive sensors
- ❑ Industrial process control
- ❑ Smart sensors and transmitters
- ❑ Blood pressure monitor
- ❑ Altimeters
- ❑ Barometers
- ❑ Diving computers
- ❑ Compasses

### Example of Sensor Application

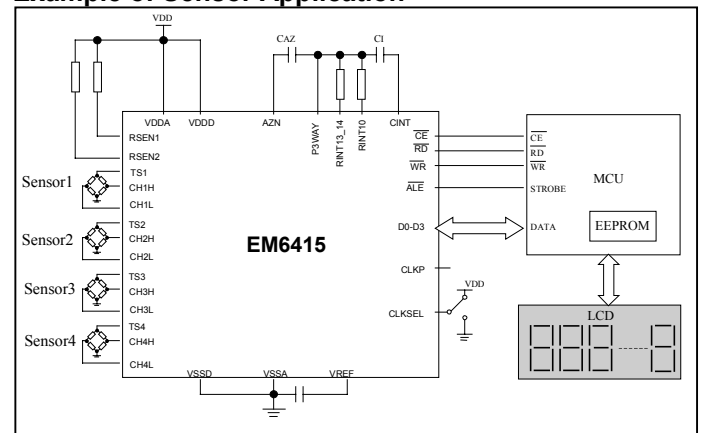

**The missing link between resistive sensors and the microcontroller**