

Sub 1 V Bluetooth Low Energy Controller

Description

The EM9301 is the first generation of low voltage and low power, fully integrated single-chip Bluetooth Low Energy (BLE) controller.

EM9301 features a low power physical layer, a link layer with an embedded security engine, a Host Controller Interface (HCI), and a powerful power management which allow operations using efficiently all type of batteries down to 0.8V. This feature is achieved thanks to the embedded high efficiency DC/DC up converter which provides the required voltage to the integrated low power RF core. Moreover, the DC/DC up converter is designed to support an external load current which can be used to supply other electronic components and sensors up to 100 mA.

EM9301 can be also ordered without DC/DC converter, for all applications where a supplied voltage from a 3 V battery or any other source such as an external LDO regulator is available in the system. In this case, the bill of material is further reduced, since no additional coil for the DC/DC up converter is needed.

EM9301 offers performances suitable for extremely low power applications. The low required number of external components, makes the EM9301 suitable for applications where form factor and small footprint are important parameters

The EM9301 is designed to act as BLE master or slave according to the Bluetooth specification V 4.0. It can be controlled by any external microcontroller featuring BLE profile and applications, through the standard BT HCI interface. UART and SPI interfaces are available as HCI transport layers. SPI interface allows the possibility to use proprietary low power mode, which can further reduce the EM9301 power consumption when the Bluetooth Low Energy RF connection is not required.

With its high level of flexibility the EM9301 is the best choice for a Bluetooth low energy companion chip.

Typical Application Schematic

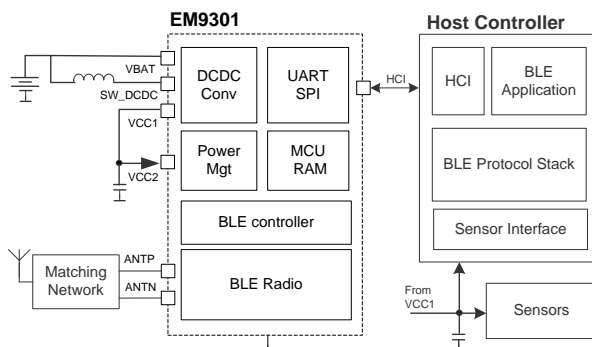

For simplicity, not all connections are shown.

Schematic refers to a EM9301 supplied by the embedded DC/DC step up converter.

Main Features

- Master and slave BLE controller compliant to Bluetooth specification 4.0
- Supply voltage down to 0.8V
- Low average current consumption
- Uses widely available, low cost 26MHz Xtal
- 1Mbps on air data rate
- 200 Ω differential impedance of antenna port
- No antenna matching elements needed through appropriate PCB antenna design
- Programmable RF output level from -20 dBm to +4dBm to optimize current consumption for a wide range of applications
- Programmable supply voltage supervisory function
- MLF 24 5x5 package

Typical Current consumptions

- 14.5 mA peak current in RF mode
- 5.0 μ A in sleep-mode (DC/DC)
- 3.0 μ A in sleep-mode (no DC/DC)
- 0.8 μ A in Off mode (no DC/DC)

Typical Applications

Bluetooth Low Energy link for

- Fitness monitoring
- Sports equipment
- Remote sensing and monitoring
- Watches with sensors and alerts
- computer peripherals
- access systems
- security equipment

Pin Assignment

