



160 KB Ultra Compact Flash Smart Card IC

Environment

- Voltage Supply Class A, B: 3.0V to 5.0V ± 10%
- 25 to +85 °C Operating Temperature
- Max supply current 10mA @ 30MHz, Class A
- Max supply current 6mA @ 30MHz, Class B
- > 4 kV ESD Protection HBM

CPU

- Software compatible CMOS 80X51 industry standard
- Accelerated architecture with 16 bit CPU performance level
- Up to 30 MHz internal CPU clock

Idle Modes

- Idle and Stop mode selectable modes
- NVM update operation with CPU in idle mode
- IO Transmission and Reception with CPU in idle mode
- Max Idle current / Clock stopped: 100 uA

Security

- Hardware Random Number Generator
- Unique chip identification number
- Notification of tampering
- IC operates under regulated voltage and internal clock
- Under / Over voltage sensors (Vcc)
- Secured layout against probing attacks

Memory Control

- General Purpose Non Volatile Memory: GPNVM
- Secure Memory Management Mechanism
- Fast Byte program: 20 us/Byte

I/O

- ISO 7816-3 compliant electrical interface
- ISO 7816-3 compliant T=0 and T=1 protocols
- ETU Timer/Counter replacing 8051 T0/T1 Timers

Memories

- 256B Local RAM (data, idata)
- 3KB XRAM (xdata space)
- 158KB GPNVM User (Flash)
- 2KB GPNVM System (Flash Boot Loader)
- 10 year data retention for EEPROM / OTPROM
- GPNVM Endurance > 100 K cycles
- Boot loader GNG and T=0 compatible
- Turbo Boot loader > 32KB/s
- Erasable Test OS option

Chip Forms

- 8" Wafer sawn or unsawn
- Back grinding and distressing options
- wafer thickness according to customer requirement
- 8 pins / 6 pins Modules

Typical Application:

- SIM cards 64KB/128KB
- Native OS

Firmware:

- Nvm Manager (Bootloader)
- Erasable Test Operating System (Pre-loaded in GPNVM)

- ✓ *Development tools fully integrated within Keil uVision2/3*
- ✓ *DevKit emulator, examples, documentation samples*

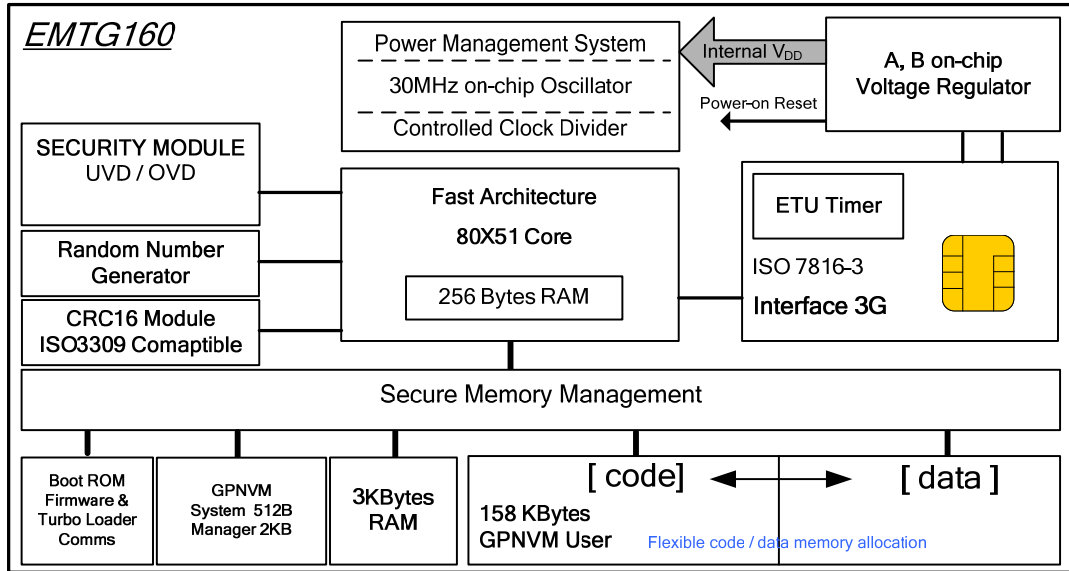



EM solution benefits:

- ✓ Powerful architecture combined with Flash flexibility
- ✓ Architecture flexibility : 1 memory
- ✓ Scalable memory : safe and fast memory spin
- ✓ Design to cost implementation
- ✓ Total flexibility in term of code / data partitioning
- ✓ Available development tools

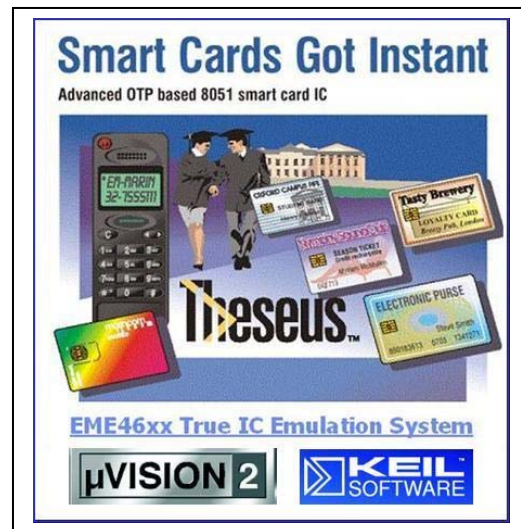

**Introduction**

EMTG160 is a member of the Theseus family of devices designed specifically for smart card applications. It is software compatible with the industry standard 8051 micro-controller, to guarantee the maximum availability of qualified software. The hardware implementation of the core is a modern design not relying on microcode, with an increase of up to 4 times on a standard 8051's clocks per instruction.

Security of the family of devices makes them particularly suitable in electronic commerce and sensitive data areas. This is accomplished in hardware, with not only protection against out of parameter operation of the device, but hardware memory management to protect against software security attacks. The CPU clock is derived from its own internal oscillator, so preventing attacks by clock manipulation, or extrapolating program execution by monitoring current variations on clock edges.

The need to support the emerging multifunction cards requires that the device under software control can download an application and run it when the device is in the field embedded in a plastic card. This application can be in the form of a script to be executed by an interpreter or as a raw binary directly executed by the processor. The device has to be protected against the downloading of attack software designed to corrupt or uncover the working or data contained in the device. Traditionally this has been a software function, which relies on the total integrity of the embedded software. The EMTG160 implements the first level of protection in hardware.

A simple and secure memory protection mechanism is relying on a flexible border between code and data space.

The General Purpose Non Volatile Memory concept allows reaching ultra low cost implementation of traditional 64KB / 96KB / 128KB EEPROM smart card ICs. All your efforts to save code footprint are optimizing your end product performances.

Best fit for code data partitioning with code size + NV data size < 160 KB.

Serial interface

EMTG160 offers a unique serial interface compliant with the ISO 7816-3 specification with several modes implemented allowing serial connections at 9600 up to 357K bits per second at 3.57MHz. EMTG160 supports T=0 asynchronous half duplex character transmission protocol, T=1 asynchronous half duplex block transmission and a proprietary T=14 protocol used for fast loading of Code into the OTP by the card manufacturer. It handles minimum guard time requirements between characters specified by ISO7816-3 specification automatically. EMTG160 is designed to be compatible with the ISO7816-3 specification defining the characteristics of Integrated Circuit Cards commonly referred to as smart cards.

Random Number Generator

The on chip random number generator is passing test based on FIPS140-2 criteria, providing a rapid stream of truly random numbers. This allows use of the random numbers generated beyond just the provision of numbers for randomising transmissions or generating keys.

Clocks

EMTG160 has its own internal oscillator this allows the core of the device to be independent of the external clock. The processor can also be clocked much faster than the IO CLK signal. This ensures the elimination of fraudulent attacks involving frequency jitter and unequal mark space ratios. The internal clock generator is connected to the core via a divider that is under the control of the software. This allows the Operating System writer to control the trade off between execution speed and power drawn by the device. Extending battery life in hand help applications where slow interfaces are involved.

Anti tampering

The EMTG160 has extensive anti tampering provision including the monitoring of the connection to the device to ensure that deviations beyond a prescribed criteria result in the device being closed down before its operating conditions are violated.

On chip voltage regulators

Several on chip regulators isolate the various elements of the device from variations and fluctuations in the supply voltage. This allows elements to be characterised precisely, as they operate at one fixed voltage, which in turn maximises the endurance of the device.

Technology

This product is using superior Flash memory SuperFlash Technology licensed from SST and SuperFlash is a registered trademark of SST (Silicon Storage Technology Inc.).



Technical Data

Absolute Maximum Ratings

Parameter	Symbol	Limit Values			Unit
		min	typical	max	
Supply Operating Volt	V_{cc}	-0.3		6	V
Voltage at remaining pin	V_{pin}	$V_{ss} - 0.3$		$V_{cc} + 0.3$	V
Power dissipation	P_{tot}			+60	mW
Storage temperature	I_{ccl}	-40		+125	°C

DC Characteristics

Parameter	Symbol	Limit Values			Unit
		min	typical	max	
Operating temperature	T_A	-25		+85	°C
Supply Voltage Class A,B	V_{cc}	2.7	3 / 5	5.5	V
Supply Current Class B	I_{cc}			6 (Note 1)	mA
Supply Current idle	I_{ccl}			200 (Note 2)	μA
Supply Current stopped	I_{ccs}			100 (Note 3)	μA

Note 1: The supply current refers to clock frequency of 5 Mhz

Note 2: The supply current at 3.3V and a clock frequency of 1 Mhz, at +25 °C

Note 3: The supply current at 3.3V and +25 °C

IO pin:

Parameter	Symbol	Conditions	min	max	Unit
H input voltage	V_{IH}	$I_{Ihmax} = \pm 20 \mu A$	$0.7 * V_{cc}$	V_{cc}	V
L input voltage	V_{IL}	$I_{ILmax} = \pm 20 \mu A$	-0.3	0.8	V
H output voltage (Note 1)	V_{OH}	$I_{Ohmax} = +20 \mu A$	$0.7 * V_{cc}$	V_{cc}	V
L output voltage	V_{OL}	$I_{Olmax} = -1mA$	0	0.4	V
Rise Fall Time	t_r, t_f	$C_{IN} = C_{OUT} = 30 pF$		1	μS

NOTE 1: Assumes 20KΩ Pull up resistor on interface device

Clock (CLK)

Parameter	Symbol	Condition	Min	Max	Unit
H output voltage	V_{OH}	$I_{Ohmax} = +20 \mu A$	$V_{cc} - 0.7$	V_{cc}	V
L output voltage	V_{OL}	$I_{Olmax} = -20 \mu A$	0	0.5	V
Rise Fall Time	t_r, t_f	$C_{IN} = C_{OUT} = 30 pF$		9% CLK period	

Reset(RST)

Parameter	Symbol	Condition	Min	Max	Unit
H output voltage	V_{OH}	$I_{Ohmax} = +20 \mu A$	$V_{cc} - 0.7$	V_{cc}	V
L output voltage	V_{OL}	$I_{Olmax} = -20 \mu A$	0	0.6	V
Rise Fall Time	t_r, t_f	$C_{IN} = C_{OUT} = 30 pF$		400	μs

EM Microelectronic-Marín SA cannot assume responsibility for use of any circuitry described other than circuitry entirely embodied in an EM Microelectronic-Marín SA product. EM Microelectronic-Marín SA reserves the right to change the circuitry and specifications without notice at any time. You are strongly urged to ensure that the information given has not been superseded by a more up-to-date version.